

# George Fern Company

Expositions • Corporate Events • Exhibits

Nationwide

3752 Crittenden Drive Louisville, Kentucky 40209-1122  
Telephone: 502.367.0254 Fax: 502.368.0284

**Deadline to  
Order Services**

**March 9, 2010**

## Louisville Career Expo

**March 24, 2010**

**Kentucky International Convention Center  
Louisville, Kentucky**

**SHOW MANAGEMENT:** Louisville Urban League  
1535 W. Broadway  
Louisville, KY 40203  
Juanita Sands  
jsands@lul.org  
502/566-3370  
502/561-6835 Fax

**MOVE-IN DATES & HOURS:** Tuesday, March 23, 2010 2:00pm - 6:00pm  
Wednesday, March 24, 2010 7:00am - 10:00am

**BOOTH EQUIPMENT:** 10' x 10' Booth  
7" x 44" ID Sign  
1-8' White Skirted Table  
2-Folding Chairs  
1-Wastebasket

**SHOW DATES & HOURS:** Wednesday, March 24, 2010 10:00am - 4:00pm

**SHOW COLORS:** Booth Drape Red/White/Black  
Aisle Carpet None

**MOVE-OUT DATE & HOURS:** Wednesday, March 24, 2010 4:00pm - 7:30pm

As the Official Service Contractor for this exposition, we are enclosing various equipment rental and service order forms for your information and use. In addition to the George Fern Company forms, you may find forms enclosed for services performed by the Convention facility or other suppliers. Please give special attention to see that forms and payments are directed to address indicated on each order form. Some services may *not* be provided by George Fern Co.

We realize that exhibiting in a convention can be complicated. If you need assistance or additional information that is not addressed here, please contact our Exhibitor Services Department at (502) 367-0254. We look forward to serving you.

George Fern Co.

### WAYS TO ORDER

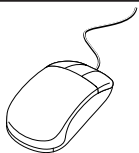

**BY INTERNET:**  
[www.georgefern.com](http://www.georgefern.com)



**BY MAIL:**  
MAIL ORDER FORMS TO:  
GEORGE FERN CO.  
3752 Crittenden Drive  
Louisville, Kentucky 40209-1122



**BY FAX:**  
SEND ORDER FORMS TO:  
(502) 368-0284  
( CREDIT CARDS ONLY )  
Our FAX line is open 24 hours



**BY PHONE:**  
Call (502) 367-0254  
With Credit Card Number

CL-5



Return to:  
**George Fern Company**  
 Expositions • Corporate Events • Exhibits  
Nationwide

**EXHIBIT FURNITURE RENTAL  
 ORDER FORM**

**DEADLINE** **March 9, 2010**

for return of this form:

3752 Crittenden Drive Louisville, Kentucky 40209-1122  
 Telephone: 502.367.0254 Fax: 502.368.0284

**Cancellation:** Cancellation after deadline will be 50% of prevailing rate.  
**Late Request:** Request after deadline will be filled as available at the standard rate.

**Color Choice:** Choices not indicated will be selected by George Fern Co.

DISPLAY TABLES - 30" high x 2' wide						DISPLAY TABLES COUNTERS - 40" high x 2' wide					
Qty.	Code	Description	Discount Rate	Standard Rate	Amount	Qty.	Code	Description	Discount Rate	Standard Rate	Amount
	223	4' long table SKIRTED 3 sides	82.00	110.75			229	4' long table SKIRTED 3 sides	104.25	140.75	
	233	6' long table SKIRTED 3 sides	104.25	140.75			239	6' long table SKIRTED 3 sides	123.50	166.75	
	253	8' long table SKIRTED 3 sides	126.25	170.50			259	8' long table SKIRTED 3 sides	148.00	199.75	
	522	4th side skirted (additional) all sizes	43.50	58.75			530	4th side skirted (additional) all sizes	57.25	77.25	
	222	4' long table NOT skirted	31.50	42.50			228	4' long table NOT skirted	41.25	55.75	
	232	6' long table NOT skirted	41.50	56.00			238	6' long table NOT skirted	52.75	71.25	
	252	8' long table NOT skirted	45.75	61.75			258	8' long table NOT skirted	57.25	77.25	
CHECK SKIRT COLOR (Includes Top Covered in White Plastic) <input type="checkbox"/> Black (4) <input type="checkbox"/> Blue (6) <input type="checkbox"/> Gold (8) <input type="checkbox"/> Burgundy (11) <input type="checkbox"/> Plum (19) <input type="checkbox"/> Green (10) <input type="checkbox"/> Gray (9) <input type="checkbox"/> Red (14) <input type="checkbox"/> Teal (18) <input type="checkbox"/> White (16)						CHECK SKIRT COLOR (Includes Top Covered in White Plastic) <input type="checkbox"/> Black (4) <input type="checkbox"/> Blue (6) <input type="checkbox"/> Gold (8) <input type="checkbox"/> Burgundy (11) <input type="checkbox"/> Plum (19) <input type="checkbox"/> Green (10) <input type="checkbox"/> Gray (9) <input type="checkbox"/> Red (14) <input type="checkbox"/> Teal (18) <input type="checkbox"/> White (16)					
CHAIRS, STOOLS, COFFEE TABLES						ACCESSORIES					
	105	Walnut Arm Chair, Grey	57.25	77.25			401	Wastebasket	14.25	19.25	
	103	Padded Side Chair, Grey	47.00	63.50			409	Chrome Bag Stand	77.75	105.00	
	101	Armless Side Chair, Black	44.00	59.50			407	Easel, tripod	24.00	32.50	
	121	Swivel Desk Chair	67.00	90.50			413	Chrome Clothes Tree	36.00	48.50	
	131	Stool - Padded with Back	47.75	64.50			435	Chrome Stanchion	23.75	32.00	
	204	Pedestal Table - 24" Dia. 18" ht.	67.00	90.50		ft.	437	White Plastic Chain (per ft.)	2.60	3.51	
	206	Pedestal Table - 24" Dia. 30" ht.	75.50	102.00			415	Garment Rack - 5' long	59.50	80.25	
	208	Pedestal Table - 24" Dia. 40" ht.	85.00	114.75		ft.	507	Special Skirting, 30" ht.	7.25	9.80	
	207	Pedestal Table - 30" Dia. 18" ht.	75.50	102.00		ft.	509	Special Skirting, 40" ht.	9.60	12.95	
	215	Pedestal Table - 30" Dia. 30" ht.	85.00	114.75		CHECK SPECIAL SKIRTING COLOR <input type="checkbox"/> Black (4) <input type="checkbox"/> Blue (6) <input type="checkbox"/> Gold (8) <input type="checkbox"/> Burgundy (11) <input type="checkbox"/> Plum (19) <input type="checkbox"/> Green (10) <input type="checkbox"/> Gray (9) <input type="checkbox"/> Red (14) <input type="checkbox"/> Teal (18) <input type="checkbox"/> White (16)					
	216	Pedestal Table - 30" Dia. 40" ht.	93.25	126.00							
	209	Pedestal Table - 36" Dia. 18" ht.	85.00	114.75							
	224	Pedestal Table - 36" Dia. 30" ht.	93.25	126.00							
	225	Pedestal Table - 36" Dia. 40" ht.	102.50	138.50							
TABLETOP RISERS - 12" Deep Covered White Plastic						SPECIAL BOOTH DRAPERIES					
	270	4' long, Single Step, 12" ht.	18.75	25.25		ft.	541	Special color siderail drapes, 36" high - Price per linear foot.	9.60	12.95	
	272	6' long, Single Step, 12" ht.	29.00	39.25		ft.	543	Special color background drapes, 8' high - Price per linear foot.	14.10	19.05	
	274	8' long, Single Step, 12" ht.	41.50	56.00		CHECK DRAPERY COLOR <input type="checkbox"/> Black (4) <input type="checkbox"/> Blue (6) <input type="checkbox"/> Gold (8) <input type="checkbox"/> Burgundy (11) <input type="checkbox"/> Plum (19) <input type="checkbox"/> Green (10) <input type="checkbox"/> Gray (9) <input type="checkbox"/> Red (14) <input type="checkbox"/> Teal (18) <input type="checkbox"/> White (16)					

**Yes, I have completed and enclosed the Payment Form**  
 No credit will be given after close of event on items or services ordered, but not received. If you have a problem please see the George Fern Co. Service Desk Personnel at the event site prior to leaving.

 **Sub Total:** \$ \_\_\_\_\_  
**6% State tax:** \$ \_\_\_\_\_  
**TOTAL:** \$ \_\_\_\_\_

Name of Event **Louisville Career Expo #4-7905-10** Booth# \_\_\_\_\_ Phone ( ) \_\_\_\_\_  
 Firm Name \_\_\_\_\_ Fax # ( ) \_\_\_\_\_  
 Address \_\_\_\_\_ E-Mail \_\_\_\_\_  
 Street City State Zip Code  
 Print/Type Name \_\_\_\_\_ Signature \_\_\_\_\_ Date \_\_\_\_\_

Return to:  
**George Fern Company**

Expositions • Corporate Events • Exhibits

Nationwide

**CARPET RENTAL  
ORDER FORM**

**DEADLINE** **March 9, 2010**

for return of this form:

3752 Crittenden Drive Louisville, Kentucky 40209-1122  
 Telephone: 502.367.0254 Fax: 502.368.0284

**Cancellation:** Cancellation after deadline will be 50% of prevailing rate.  
**Late Request:** Request after deadline will be filled as available at the standard rate.

**Color Choice:** Choices not indicated will be selected by George Fern Co.

**PLUSH CARPET**

**Plush carpet is an upgraded 34oz. carpet, available in 12 decorator colors. Swatches will be sent to you upon request.**

Cut carpet is designed for use in standard size exhibit booths. If complete area carpet for your space is desired, order by the complete area square footage. Complete area carpet includes trimming, seaming, wastage, edge taping, rental and removal for carpet specifically cut to your exact measurements.

CARPET & PADDING PACKAGE	DISCOUNT RATE	STANDARD RATE	CARPET ONLY	DISCOUNT RATE	STANDARD RATE
<input type="checkbox"/> 10 ft x 10 ft Carpet & Padding (335) ---	\$ 265.50	<b>\$ 358.50</b>	<input type="checkbox"/> 10 ft x 10 ft Carpet only (331) -----	\$ 197.50	<b>\$ 266.75</b>
<input type="checkbox"/> 10 ft x 20 ft Carpet & Padding (336) --	\$ 531.00	<b>\$ 716.75</b>	<input type="checkbox"/> 10 ft x 20 ft Carpet only (332) -----	\$ 395.00	<b>\$ 533.25</b>
<input type="checkbox"/> 10 ft x 30 ft Carpet & Padding (337) ---	\$ 796.50	<b>\$1,075.25</b>	<input type="checkbox"/> 10 ft x 30 ft Carpet only (333) -----	\$ 592.50	<b>\$ 800.00</b>
<input type="checkbox"/> 10 ft x 40 ft Carpet & Padding (338) ---	\$1,062.00	<b>\$1,433.75</b>	<input type="checkbox"/> 10 ft x 40 ft Carpet only (334) -----	\$ 790.00	<b>\$1,066.50</b>

**Plush Complete Area Carpet (minimum order 100 sq/ft.)**

	DISCOUNT RATE	STANDARD RATE	TOTAL
<input type="checkbox"/> Plush Carpet Sq/ft. (328) _____ FT x _____ FT = _____ SQ FT @	\$ 3.35 / sq.ft.	<b>\$ 4.52 / sq.ft.</b>	= \$ _____
<input type="checkbox"/> Padded Area Size (350) _____ FT x _____ FT = _____ SQ FT @	\$ .80 / sq.ft.	<b>\$ 1.08 / sq.ft.</b>	= \$ _____
<input type="checkbox"/> Plastic Covering Area (360) _____ FT x _____ FT = _____ SQ FT @	\$ .14 / sq.ft.	<b>\$ .19 / sq.ft.</b>	= \$ _____

CHECK COLOR DESIRED FOR PLUSH CARPET:

- |  |  |  |   |
|--|--|--|---|
| <input type="checkbox"/> White - (63)        | <input type="checkbox"/> Burgundy - (48) | <input type="checkbox"/> Gray Pearl - (64) | <input type="checkbox"/> Blue Mist - (68)   |
| <input type="checkbox"/> French Beige - (65) | <input type="checkbox"/> Mocha - (61)    | <input type="checkbox"/> Charcoal - (66)   | <input type="checkbox"/> Colony Blue - (62) |
| <input type="checkbox"/> Cherry Red - (46)   | <input type="checkbox"/> Emerald - (67)  | <input type="checkbox"/> Ebony - (47)      | <input type="checkbox"/> Berry - (51)       |

**TRADITIONAL CARPET**

Cut carpet is designed for use in standard size exhibit booths. If complete area carpet for your space is desired, order by the complete area square footage. Complete area carpet includes trimming, seaming, wastage, edge taping, rental and removal for carpet specifically cut to your exact measurements.

CARPET & PADDING PACKAGE	DISCOUNT RATE	STANDARD RATE	CARPET ONLY	DISCOUNT RATE	STANDARD RATE
<input type="checkbox"/> 9 ft x 10 ft Carpet & Padding (309) ----	\$ 198.75	<b>\$ 268.25</b>	<input type="checkbox"/> 9 ft x 10 ft Carpet only (301) -----	\$ 137.50	<b>\$ 185.75</b>
<input type="checkbox"/> 9 ft x 20 ft Carpet & Padding (310) ----	\$ 397.50	<b>\$ 536.75</b>	<input type="checkbox"/> 9 ft x 20 ft Carpet only (302) -----	\$ 275.00	<b>\$ 371.25</b>
<input type="checkbox"/> 9 ft x 30 ft Carpet & Padding (311) ----	\$ 596.00	<b>\$ 804.50</b>	<input type="checkbox"/> 9 ft x 30 ft Carpet only (303) -----	\$ 412.50	<b>\$ 557.00</b>
<input type="checkbox"/> 9 ft x 40 ft Carpet & Padding (312) ----	\$ 794.75	<b>\$1,073.00</b>	<input type="checkbox"/> 9 ft x 40 ft Carpet only (304) -----	\$ 550.00	<b>\$ 742.50</b>

**Traditional Complete Area Carpet (minimum order 100 sq/ft.)**

	DISCOUNT RATE	STANDARD RATE	TOTAL
<input type="checkbox"/> Traditional Carpet Sq/ft. (314) _____ FT x _____ FT = _____ SQ FT @	\$ 2.95 / sq.ft.	<b>\$ 3.98 / sq.ft.</b>	= \$ _____
<input type="checkbox"/> Padded Area Size (350) _____ FT x _____ FT = _____ SQ FT @	\$ .80 / sq.ft.	<b>\$ 1.08 / sq.ft.</b>	= \$ _____
<input type="checkbox"/> Plastic Covering Area (360) _____ FT x _____ FT = _____ SQ FT @	\$ .14 / sq.ft.	<b>\$ .19 / sq.ft.</b>	= \$ _____

CHECK COLOR DESIRED FOR TRADITIONAL CARPET:

- |                                    |                                    |                                   |                                     |                                      |                                    |                                       |                                       |
|------------------------------------|------------------------------------|-----------------------------------|-------------------------------------|--------------------------------------|------------------------------------|---------------------------------------|---------------------------------------|
| <input type="checkbox"/> Blue (06) | <input type="checkbox"/> Gray (09) | <input type="checkbox"/> Red (14) | <input type="checkbox"/> Black (04) | <input type="checkbox"/> Maroon (11) | <input type="checkbox"/> Plum (19) | <input type="checkbox"/> Seafoam (20) | <input type="checkbox"/> Madison (21) |
|------------------------------------|------------------------------------|-----------------------------------|-------------------------------------|--------------------------------------|------------------------------------|---------------------------------------|---------------------------------------|

**Yes, I have completed and enclosed the Payment Form**

**Sub Total:** \$ \_\_\_\_\_  
 6% State tax: \$ \_\_\_\_\_  
**TOTAL:** \$ \_\_\_\_\_

No credit will be given after close of event on items or services ordered, but not received. If you have a problem please see the George Fern Co. Service Personnel at the event site prior to opening.

Name of Event **Louisville Career Expo #4-7905-10** Booth# \_\_\_\_\_ Phone ( ) \_\_\_\_\_  
 Firm Name \_\_\_\_\_ Fax # ( ) \_\_\_\_\_  
 Address \_\_\_\_\_ E-Mail \_\_\_\_\_  
 Street City State Zip Code  
 Print/Type Name \_\_\_\_\_ Signature \_\_\_\_\_ Date \_\_\_\_\_

Return to:  
**George Fern Company**

Expositions • Corporate Events • Exhibits

Nationwide

3752 Crittenden Drive Louisville, Kentucky 40209-1122  
 Telephone: 502.367.0254 Fax: 502.368.0284

**CLEANING SERVICE  
 ORDER FORM**

**DEADLINE** **March 9, 2010**  
 for return of this form:

**Cancellation:** Cancellation of any portion of Cleaning order after deadline, and before service, will be charged at 25% of prevailing rate.

The cleaning services provided by the exhibit hall include only a general sweeping of the aisle. All rental carpets ordered from the Geo. E. Fern Co. are installed in clean condition. Any cleaning service required within your booth space for debris accumulated during set-up and exhibit hours should be ordered below.

**VACUUMING / SHAMPOO**

All rates are based on the total square footage of your exhibit space. (100 square foot minimum)

**Please check preference below:**

- (903) DAILY - Vacuum carpet, empty wastebaskets and clean ashtrays before initial opening of exhibit and DAILY thereafter ..... \$ .30 Per Sq/ft. per day
  - (931) DAILY - Over 1000 Sq.Ft. .... \$ .25 Per Sq/ft. per day
  - (901) ONCE Vacuum carpet, empty wastebaskets and clean ashtrays ONCE before opening of exhibit ..... \$ .33 Per Sq/ft.
  - (905) SHAMPOO - ONCE before initial opening of exhibit ..... \$ .55 Per Sq/ft.
- There will be an additional charge for cleaning carpets that are subjected to excessive wear and tear such as wood or metal shavings generated by demonstrations in the booth, food sampling, landscape, etc.

**PORTER SERVICE**

Empty wastebasket and police exhibit space at two hour intervals during show hours.

- (915) Periodical Porter Service ..... \$220.00 Per Day

**Please check preference below:**

- DAILY
- ONCE --- Specify Day: \_\_\_\_\_ Date: \_\_\_\_\_
- OTHER --- Specify Day(s) Date(s) \_\_\_\_\_

**DISPLAY WIPE DOWN**

- (919) Display Wipe Down before initial opening (4 Hour minimum per day) ..... \$ 58.50 per hr. S/T or \$117.00 per hr. O/T
- (920) Display Wipe Down daily (4 Hour minimum per day) ..... \$ 58.50 per hr. S/T or \$117.00 per hr. O/T

**SPECIAL INSTRUCTIONS / CONCERNS**

\_\_\_\_\_  
 \_\_\_\_\_  
 \_\_\_\_\_

**ESTIMATE CLEANING SERVICES COST FOR ADVANCE PAYMENT**

- \* Exhibit Space: \_\_\_\_\_ ft. x ft. \_\_\_\_\_ = \_\_\_\_\_ sq. ft. (100 sq. ft. min.) x \_\_\_\_\_ per sq. ft. x \_\_\_\_\_ days = \$ \_\_\_\_\_
- \* Porter Service: \_\_\_\_\_ days x \$220.00 per day \_\_\_\_\_ = \$ \_\_\_\_\_
- \* Display Cleaning: \_\_\_\_\_ hours (4 Hour minimum per day) x \_\_\_\_\_ day(s) x \$ 58.50 per hr. S/T or \$117.00 per hr. O/T = \$ \_\_\_\_\_

**Yes, I have completed and enclosed the Payment Form** **Sub Total:** \$ \_\_\_\_\_  
 No credit will be given after close of event on items or services ordered, but not received. If you have a problem please see George Fern Co. Service Personnel at the event site prior to opening. **TOTAL:** \$ \_\_\_\_\_

Name of Event **Louisville Career Expo #4-7905-10** Booth# \_\_\_\_\_ Phone ( ) \_\_\_\_\_  
 Firm Name \_\_\_\_\_ Fax # ( ) \_\_\_\_\_  
 Address \_\_\_\_\_ E-Mail \_\_\_\_\_  
 Street City State Zip Code  
 Print/Type Name \_\_\_\_\_ Signature \_\_\_\_\_ Date \_\_\_\_\_

Return to:  
**George Fern Company**  
**Expositions • Corporate Events • Exhibits**  
Nationwide

3752 Crittenden Drive Louisville, Kentucky 40209-1122  
 Telephone: 502.367.0254 Fax: 502.368.0284

**DISPLAY LABOR SERVICE  
 ORDER FORM**

(THIS FORM IS NOT FOR UNLOADING AND RELOADING -  
 SEE DRAYAGE SERVICE)

**DEADLINE** **March 9, 2010**

for return of this form:

**Cancellation:** Cancellation of any portion of labor order within 48 hours of start will be charged 1 hour minimum per man at the applicable hourly rate.

**Late Request:** Request received on-site will be filled as work force is available.

**PLAN A - SUPERVISION BY GEORGE FERN CO.**

To save time and alleviate exhibitor supervision, Plan A (Supervision by George Fern Co.) is provided so that exhibits may be installed prior to the exhibitor's arrival. All pertinent information should be directed to us, including blueprints, photographs, shipping information and set-up instructions. Professionally trained personnel are used on installation/dismantles, and where possible, all work is performed on straight time. Charge for supervised service is 30% (with a minimum of \$50.00 per installation and/or dismantle) of the total labor bill. **Please provide an emergency contact telephone number:** ( \_\_\_\_\_ ) \_\_\_\_\_.

ORDER:	Number of Men Required Minimum of two	Estimated Hours (one hour increments) Each Man
(1017) Labor for Installation		
(1019) Labor for Dismantle		

**PLAN B - SUPERVISION BY EXHIBITOR PERSONNEL**

Starting time can be guaranteed only in those instances where men are requested for the start of the working day, which is 8:00 A.M., unless official set-up time is set to begin later in the day. While every attempt will be made to provide men at a time requested subsequent to 8:00 A.M. (or official set-up time), such starting time must be approximate, since men are assigned to jobs at the start of the day and it is impossible to gauge exact time of completion of first job assignment. **It is important that exhibit representative check in at service desk to pick up labor ordered.** Exhibit representative must also check the labor back in at the service desk upon completion of work. All work to be done under supervision of the exhibitor or his representative.

ORDER:	Number of Men Required	Estimated Hours (one hour increments) Each Man	Start Time	Start Date	No. Days
(1017) Labor for Installation					
(1019) Labor for Dismantle					

Supervisor will be: \_\_\_\_\_  
 Phone: ( \_\_\_\_\_ ) \_\_\_\_\_

**Note: If exhibitor fails to pick up men at time ordered, a one hour per man no-show charge will be assessed.**

**RATES: ESTIMATED DISPLAY LABOR COST FOR ADVANCED PAYMENT**

Charges for labor service are based on prevailing rates of labor and materials. All labor before 8:00 A.M. and after 4:30 P.M. weekdays and all hours Saturday, Sunday, and holidays will be charged at overtime rate. Minimum charge one (1) hour per man, billed in one (1) hour increments. For information and cost relative to unloading and reloading please see the Shipping Information and Service Order Form enclosed. This form is not intended for the ordering of unloading/loading services. **SEE DRAYAGE SERVICE FORM.**

**INSTALLATION**

\_\_\_\_\_ # of men x \_\_\_\_\_ # of hours per man x \_\_\_\_\_ # of days = \_\_\_\_\_ Total straight time hours x \$ 58.50 / hr. = \_\_\_\_\_  
 \_\_\_\_\_ # of men x \_\_\_\_\_ # of hours per man x \_\_\_\_\_ # of days = \_\_\_\_\_ Total over time hours x \$ 117.00 / hr. = \_\_\_\_\_  
**Add 30% if supervised by George Fern Co. (\$ 50.00 min.) = \_\_\_\_\_**

**DISMANTLE**

\_\_\_\_\_ # of men x \_\_\_\_\_ # of hours per man x \_\_\_\_\_ # of days = \_\_\_\_\_ Total straight time hours x \$ 58.50 / hr. = \_\_\_\_\_  
 \_\_\_\_\_ # of men x \_\_\_\_\_ # of hours per man x \_\_\_\_\_ # of days = \_\_\_\_\_ Total over time hours x \$ 117.00 / hr. = \_\_\_\_\_  
**Add 30% if supervised by George Fern Co. (\$ 50.00 min.) = \_\_\_\_\_**

**NOTE:**

Your company is encouraged to carry insurance covering potential damages or loss associated with your display. The George Fern Company will NOT be responsible for damage or loss of display materials. In any case, the liability of the George Fern Company will be limited to a maximum of 50% of the total labor bill, not to exceed \$1000.

**Yes, I have completed and enclosed the Payment Form**

No credit will be given after close of event on items or services ordered, but not received.

If you have a problem please see George Fern Co. Service Personnel at the event site prior to opening.

**Sub Total:** \$ \_\_\_\_\_  
**NO TAX ON LABOR**  
**TOTAL:** \$ \_\_\_\_\_

Name of Event **Louisville Career Expo #4-7905-10** Booth# \_\_\_\_\_ Phone ( \_\_\_\_\_ ) \_\_\_\_\_  
 Firm Name \_\_\_\_\_ Fax # ( \_\_\_\_\_ ) \_\_\_\_\_  
 Address \_\_\_\_\_ E-Mail \_\_\_\_\_  
 Street City State Zip Code  
 Print/Type Name \_\_\_\_\_ Signature \_\_\_\_\_ Date \_\_\_\_\_

All orders are subject to the terms and conditions as outlined on the payment form.

Return to:  
**George Fern Company**  
**Expositions • Corporate Events • Exhibits**  
Nationwide

3752 Crittenden Drive Louisville, Kentucky 40209-1122  
 Telephone: 502.367.0254 Fax: 502.368.0284

**FORKLIFT WITH OPERATOR  
 SERVICE ORDER FORM**

(THIS FORM IS NOT FOR UNLOADING AND RELOADING -  
 SEE DRAYAGE SERVICE)

**DEADLINE** **March 9, 2010**

for return of this form:

**Cancellation:** Cancellation of any portion of labor order within 48 hours of start will be charged 1 hour minimum per man at the applicable hourly rate.

**Late Request:** Request received on-site will be filled as work force is available.

**LABOR WITH FORKLIFT TO RIG IN BOOTH**

If your exhibit includes large header signs, cantilever structures, heavy display components or machinery which cannot be lifted in place by display carpenters, you will require a forklift with operator in your booth for installation and removal. The forklift with operator cost to the exhibitor is billed at hourly increments with a one (1) hour minimum. If additional decorators are required, prevailing decorator labor charges will be assessed. If you have forklift questions, please call the George Fern Co. at 502-367-0254. **It is important that exhibit representative check in at service desk to pick up labor ordered.**

**ORDER FOR FORKLIFT FOR IN-BOOTH WORK**

ORDER:	Number of Men Required	Estimated Hours (one hour increments) Each Man	Start Date	Start Time	Estimated Finish Time	Estimated Total Time
(1005) Labor for Installation						
(1007) Labor for Dismantle						

**RATES: ESTIMATED RIGGING LABOR COST FOR ADVANCE PAYMENT**

Charges for forklift are based on prevailing rates for labor and materials. All labor before 8:00 A.M. and after 4:30 P.M. weekdays, all day Saturday, Sunday and holidays will be charged at the Overtime rate. Forklift and operator is billed at hourly rate with a minimum charge of one (1) hour per man, billed in one (1) hour increments. For information and costs related to Labor To Install Displays, Labor To Hang Signs, or Labor For Unloading Services - refer to other forms in this Service Kit.

<b>INSTALLATION</b>	
_____ # of Fork/operators x _____ # of hours per man x _____ # of days _____ Total straight time hours x \$158.50 / hr.	= _____
_____ # of Fork/operators x _____ # of hours per man x _____ # of days _____ Total over time hours x \$217.00 / hr.	= _____
<b>Add 30% if supervised by George Fern Co. (\$ 50.00 min.)</b>	= _____
<b>DISMANTLE</b>	
_____ # of Fork/operators x _____ # of hours per man x _____ # of days _____ Total straight time hours x \$158.50 / hr.	= _____
_____ # of Fork/operators x _____ # of hours per man x _____ # of days _____ Total over time hours x \$217.00 / hr.	= _____
<b>Add 30% if supervised by George Fern Co. (\$ 50.00 min.)</b>	= _____

**NOTE:**  
 Your company is encouraged to carry insurance covering potential damages or loss associated with your display. The George Fern Company will NOT be responsible for damage or loss of display materials. In any case, the liability of the George Fern Company will be limited to a maximum of 50% of the total labor bill, not to exceed \$1000.

**Yes, I have completed and enclosed the Payment Form**  
 No credit will be given after close of event on items or services ordered, but not received.  
 If you have a problem please see George Fern Co. Service Personnel at the event site prior to opening.

 **Sub Total:** \$ \_\_\_\_\_  
 \$ **NO TAX ON LABOR** \_\_\_\_\_  
**TOTAL:** \$ \_\_\_\_\_

Name of Event **Louisville Career Expo #4-7905-10** Booth# \_\_\_\_\_ Phone ( ) \_\_\_\_\_  
 Firm Name \_\_\_\_\_ Fax # ( ) \_\_\_\_\_  
 Address \_\_\_\_\_ E-Mail \_\_\_\_\_  
 Street City State Zip Code  
 Print/Type Name \_\_\_\_\_ Signature \_\_\_\_\_ Date \_\_\_\_\_

Return to:  
**George Fern Company**  
 Expositions • Corporate Events • Exhibits

Nationwide

3752 Crittenden Drive Louisville, Kentucky 40209-1122  
 Telephone: 502.367.0254 Fax: 502.368.0284

**SHIPPING INFORMATION AND  
 FREIGHT SERVICE ORDER FORM -  
 PAGE 1**

**DEADLINE March 9, 2010**

for return of this form:

**Important:** Complete the Freight Payment computation below based upon your estimated shipments and return this form with your payment and the Payment Authorization form included with this service kit.

**INSTRUCTIONS**

- All shipments must be sent prepaid. Collect shipments will not be accepted.
- The Advance Warehouse will **ONLY** accept packaged shipments, including crates, boxes and skids. Loose shipments will not be accepted unless the delivering carrier cannot deliver the shipment to the facility, in which case a 50% surcharge will be added to the warehouse rate.
- Loose, uncrated, van, or specializes carrier shipments should be sent **DIRECTLY** to the **CONVENTION FACILITY** to arrive **AFTER 8:00 AM** on the first day of the exhibitor installation.
- Consignment or delivery of a shipment to George Fern Co., or it's subcontractors by an Exhibitor or Shipper on behalf of the Exhibitor will be construed as an acceptance by the Exhibitor of the Freight Terms and Conditions on the front and reverse of this page.
- Outbound bills of lading must be filled out and turned into the exhibitor service desk. If designated carriers are to be used, the exhibitor must make those arrangements directly with the carrier. If designated carrier fails to show in required time frame, shipment will be reconsigned to house carrier. If no return information is provided, freight will be forced to house carrier.

**ADVANCE RECEIVING WAREHOUSE**

\* Label each piece of your shipment(s) as follows:  
 TO: (NAME OF EXHIBITING COMPANY)  
 c/o George Fern Co.  
 3752 Crittenden Drive  
 Louisville, KY 40209  
 Event: Louisville Career Expo  
 Exhibitor Space #: YOUR SPACE # ASSIGNMENT  
 Must arrive by: Monday, March 22, 2010

**DIRECT TO EVENT SITE**

\* Label each piece of your shipment(s) as follows:  
 TO: (NAME OF EXHIBITING COMPANY)  
 c/o George Fern Co.  
 KY International Convention Center  
 221 4th Ave., 3rd Street Dock, Louisville, KY 40202  
 Event: Louisville Career Expo  
 Exhibitor Space #: YOUR SPACE # ASSIGNMENT  
 Target arrival on: Tuesday, March 23, 2010

**FREIGHT RATE SCHEDULE**

Rates below include receipt of your freight; delivery to the booth; storage; and return of empty crates; and the end of the show movement of your freight from the booth to the dock and reloading on trucks. Cost for freight per cwt (100 lbs or fraction) with a **200 lb. minimum per shipment applies.**

CATEGORY	DESCRIPTION	RECEIVED AT	RATE/CWT.
A	Crated or skidded shipments to	Advance Warehouse	67.50
B	Crated or skidded shipments via van lines or specialized carriers, Fed-Ex, UPS, or US Mail.	Advance Warehouse	84.38
C	Shipments requiring special handling, i.e. loose, uncrated, or late freight to	Advance Warehouse	101.25
D	Crated or skidded shipments to	Event Site	62.50
E	Crated or skidded shipments via van lines or specialized carriers, Fed-Ex, UPS, or US Mail.	Event Site	78.13
F	Shipments requiring special handling, i.e. loose, uncrated, or early freight to	Event Site	93.75
P	Small Package Shipment (shipments not exceeding 50 lbs per shipment) via FedEx, UPS or Overnight Carrier to the Event Site.	Event Site	\$35.00 1st carton \$15.00 ea addl carton

**FREIGHT PAYMENT COMPUTATION**

Enter estimated total pounds of all your shipments by rounding up each total shipment weight to the nearest 100 pounds (i.e. one 232 lb. shipment of any number of pieces would be figured as 300 lbs., 590 lbs. of any number of pieces would be figured as 600 lbs., 705 lbs. as 800 lbs., etc.) any shipment with a total of 200 lbs. or less should be calculated at 200 lb. minimum

Category (A,B,C,D,E,F)	Numbers of Pieces	Weight (Min. 200 lbs.)	Rate/CWT	Total
Shipment 1	_____	_____ lbs.	x _____	= \$ _____
Shipment 2	_____	_____ lbs.	x _____	= \$ _____
Shipment 3	_____	_____ lbs.	x _____	= \$ _____

**Yes, I have completed and enclosed the Payment Form**

No credit will be given after close of event on items or services ordered, but not received. If you have a problem please see the George Fern Co. Service Desk Personnel at the event site prior to leaving.

Please be sure to read both pages of this SHIPPING INFORMATION AND DRAYAGE SERVICE ORDER FORM. Other conditions are applicable as stated on 2nd page.



**Sub Total:** \$ \_\_\_\_\_  
**TOTAL:** \$ NO TAX ON DRAYAGE SERVICE \_\_\_\_\_

Name of Event **Louisville Career Expo #4-7905-10** Booth# \_\_\_\_\_ Phone ( ) \_\_\_\_\_  
 Firm Name \_\_\_\_\_ Fax # ( ) \_\_\_\_\_  
 Address \_\_\_\_\_ E-Mail \_\_\_\_\_  
 Street City State Zip Code  
 Print/Type Name \_\_\_\_\_ Signature \_\_\_\_\_ Date \_\_\_\_\_

Return to:  
**George Fern Company**  
**Expositions • Corporate Events • Exhibits**  
Nationwide

**SHIPPING INFORMATION AND  
 FREIGHT SERVICE ORDER FORM -  
 PAGE 2**

3752 Crittenden Drive Louisville, Kentucky 40209-1122  
 Telephone: 502.367.0254 Fax: 502.368.0284

**DEADLINE** **March 9, 2010**  
 for return of this form:

George Fern Co. must be advised (3) three weeks in advance of delivery date of any oversized freight (single pieces over 3500 lbs. or odd shaped pieces) which will require unloading / reloading.

**MISCELLANEOUS DRAYAGE SERVICES / COST AND GENERAL INFORMATION**

**SPECIAL SERVICES AND RATES** - (2201) Steel banding or (1039) shrink wrap for the packaging of displays and equipment is available at the Drayage Contractors service desk for \$.75 per lin. ft. plus (1037) labor at prevailing rates. (702) Fork lifts and drivers are available for particular spotting of equipment with-in your exhibit space After delivery to your exhibit space at prevailing rates for equipment and labor. Please order this service in advance, see **“Display Labor and Inbooth Forklift Service Order Form”**. (9997) Mobile equipment will be moved into and out of the exhibit facility for \$ 100.00 per round trip. This service MUST be scheduled in advance - *PLEASE CALL*.

**COLLECT SHIPMENTS** may be refused or accepted at the option of the Official Drayage Contractor. In cases where the Drayage Contractor elects to receive such shipments, the responsible exhibitor or shipper will be notified immediately and payment in full for all charges due must be wired to the Drayage Contractor within 24 hours. A twenty-five (25%) special service surcharge will be added to the freight bill for handling any consignments under these conditions. A \$ 10.00 MINIMUM fee will apply to this service.

**HAULING TO OR FROM LOCAL FACILITIES** - (706) Local delivery/pick-up will be charged at prevailing rates; *In addition to appropriate cwt. charges for drayage services rendered.*

**INBOUND AND OUTBOUND TRAFFIC SCHEDULES** are the responsibility of George Fern Co. / the Official Drayage Contractor. To assure orderly and expeditious handling of exhibit material into and out of the event facility, it is required that exhibitors, including local companies, clear all movement of exhibit material through the Drayage Contractor, who is prepared to handle local pickups and deliveries on a co-ordinated schedule. It is also recommended that in order to minimize congestion and comply with union requirements all shipments be channeled through the Official Drayage Contractor.

**OUTBOUND SHIPPING INSTRUCTIONS** should be given to the Official Drayage Contractor at the Convention Center Service area during the Exposition or Immediately after its close. If outbound shipping information is available prior to show commencement, forward instructions to the Drayage Contractor. All bills of lading and shipping instructions covering outbound shipments will be checked at the time of actual loading and corrections made where discrepancies exist. Freight remaining on the exhibit floor without proper instructions for disposition will be removed by the Drayage Contractor and shipped with the information available at the time. Under no circumstances will the Drayage Contractor be liable for shipping errors subsequent to the convention unless it has received specific written instructions and has failed to honor them.

**DAMAGE TO EXHIBITS** while they are being loaded, unloaded or conveyed to the various booths or common carrier by the Drayage Contractor will be its responsibility. The Drayage Contractor **WILL NOT** be responsible for damage to materials improperly packed, concealed damage, loss or theft of exhibitors materials after same have been delivered to the booth, or before materials have been picked up for loading out of the booth. In any case, the liability of the Drayage Contractor is limited to \$.10 per pound/per article, with a maximum of \$ 50.00 per item, and a maximum of \$ 1,000.00 per shipment. The shipper is encouraged to make arrangements with its insurance carrier if values of articles or shipments are in excess of those stated above.

**EXHIBITS LOSS OR DISAPPEARANCE** The George Fern Company and its subcontractors are not, and cannot be, responsible for loss or disappearance of the material of the exhibitor after such material has been delivered to the Exhibitor’s booth. Relative to inbound shipments, there may be a lapse of time between the delivery of shipment(s) to the applicable booth by the George Fern Company or its subcontractors, and the arrival of Exhibitor’s representative at the booth. During such time the shipment(s) will be left unattended in the booth. The George Fern Company and its subcontractors shall not be responsible for any loss or damage that may occur during such period.

Similarly, the George Fern Company and its subcontractors cannot be responsible for loss or disappearance of Exhibitor’s material before Exhibitor’s material is picked up from the Exhibitor’s booth for loading after the exhibition. All bills-of-lading covering outgoing shipments that are given to the George Fern Company by the Exhibitor will be checked at the time of pick-up from the booth, and corrections will be made at such time if discrepancies exist. Relative to outgoing shipments, it is possible that there will be a lapse of time between the completion of the packing and the pick up of material from the booths for loading onto a carrier, and during such time the shipment(s) will be left unattended in the booth. The George Fern Company and its subcontractors shall not be responsible of any loss or damage that may occur during such period. The George Fern Company and its subcontractors will adjust the quantities of items on any bill-of-lading submitted to the George Fern Company or its subcontractors to conform to the actual count of such items in the booth at the time of pick-up and shipment.

**DISPUTES** In the event of any dispute between an Exhibitor and the George Fern Company relative to any loss of or damage to such Exhibitor’s material, such Exhibitor shall not be entitled to and shall not withhold payment of any amount due to the George Fern Company for any services provided by the George Fern Company as any offset against the amount of any alleged loss or damage. Instead, such Exhibitor shall pay the George Fern Company within thirty days from the close of the exhibition to which Exhibitor’s shipment(s) relates(s) for all service, and such Exhibitor shall pursue any claim against the George Fern Company independently as a completely separate transaction to be resolved on its own merits. No claims for loss or damage will be considered until payment in full for all services performed by the George Fern Company has been received.

**INSURANCE** Exhibitors are urged to carry all-risk floater insurance covering their materials against damage, loss, theft and all hazards from the time shipment is made prior to the show until shipments are returned after the show.

**EXHIBITS TO BE STORED** (9998) will be charged at a minimum monthly rate of \$ 20.00 or a rate of \$ 2.00 cwt. per month or fraction thereof. No charge will be made for inbound shipments when received 14 days or less prior to the event. Please call if 15 day or longer storage is required.

---

Name of Event **Louisville Career Expo #4-7905-10** Booth# \_\_\_\_\_ Phone ( ) \_\_\_\_\_  
 Firm Name \_\_\_\_\_ Fax # ( ) \_\_\_\_\_  
 Address \_\_\_\_\_ E-Mail \_\_\_\_\_  
 Street City State Zip Code  
 Print/Type Name \_\_\_\_\_ Signature \_\_\_\_\_ Date \_\_\_\_\_

**RUSH CONVENTION EXHIBIT MATERIAL**

**FOR ADVANCE WAREHOUSE ONLY**

**MUST BE RECEIVED BY:**

**Monday, March 22, 2010**

**To:**

( Your Company Name)

**SITE: George Fern Company  
3752 Crittenden Drive  
Louisville, KY 40209**

**Attn: Louisville Career Expo**

**Booth Number:** \_\_\_\_\_

Number \_\_\_\_\_ of \_\_\_\_\_ pieces

**RUSH CONVENTION EXHIBIT MATERIAL**

**FOR ADVANCE WAREHOUSE ONLY**

**MUST BE RECEIVED BY:**

**Monday, March 22, 2010**

**To:**

( Your Company Name)

**SITE: George Fern Company  
3752 Crittenden Drive  
Louisville, KY 40209**

**Attn: Louisville Career Expo**

**Booth Number:** \_\_\_\_\_

Number \_\_\_\_\_ of \_\_\_\_\_ pieces

**RUSH CONVENTION EXHIBIT MATERIAL**

**FOR DIRECT TO SHOW SITE**

**MUST TARGET DELIVERY FOR:**

**Tuesday, March 23, 2010**

( Do **NOT** Deliver Before)

**To:**

( Your Company Name)

**SITE: George Fern Company  
Kentucky International Convention Center  
221 4th Ave., 3rd St. Dock  
Louisville, KY 40202  
Attn: Louisville Career Expo**

**Booth Number:** \_\_\_\_\_

Number \_\_\_\_\_ of \_\_\_\_\_ pieces

**RUSH CONVENTION EXHIBIT MATERIAL**

**FOR DIRECT TO SHOW SITE**

**MUST TARGET DELIVERY FOR:**

**Tuesday, March 23, 2010**

( Do **NOT** Deliver Before)

**To:**

( Your Company Name)

**SITE: George Fern Company  
Kentucky International Convention Center  
221 4th Ave., 3rd St. Dock  
Louisville, KY 40202  
Attn: Louisville Career Expo**

**Booth Number:** \_\_\_\_\_

Number \_\_\_\_\_ of \_\_\_\_\_ pieces

**OUTBOUND SHIPPING**  
**PREPRINTED BILL OF**  
**LADING & SHIPPING LABELS**

Louisville Career Expo

Booth Number: \_\_\_\_\_

Company Name: \_\_\_\_\_

The George Fern Company will prepare your outbound Bill of Lading Shipping & Labels if you choose to fill out the required information below and return to our office, via fax 502/368-0284, by the deadline date of **March 9, 2010**. If you do not choose to complete and return this form, there will be blank Bills of Lading and Shipping Labels available at the George Fern Service Desk on-site.

**EVERY OUTBOUND SHIPMENT REQUIRES A GEORGE FERN COMPANY BILL OF LADING FOR EACH DESTINATION. EACH SHIPMENT MUST ALSO BE LABELED.**

Ship to:

\_\_\_\_\_  
(Company Name)

\_\_\_\_\_  
(Street Address)

\_\_\_\_\_  
(City/State/Zip code)

\_\_\_\_\_  
(Attention)

\_\_\_\_\_  
(Telephone)

Requested Delivery Date & Time: \_\_\_\_\_  
(If Necessary)

Quantity of Labels Required: \_\_\_\_\_ Carrier: \_\_\_\_\_

**OUR HOUSE CARRIER IS YRC. YOU MAY USE ANOTHER CARRIER OF YOUR CHOICE, HOWEVER YOU WILL NEED TO SCHEDULE THE PICK UP. ALL FREIGHT CARRIERS MUST BE CHECKED IN NO LATER THAN: Wednesday, March 24, 2010, 6pm**

The facility address for carrier pick up is, KICC, 221 4th Ave., 3rd Steet Dock, Louisville, KY 40202

Freight Charges to:

\_\_\_\_\_  
(Company Name)

\_\_\_\_\_  
(Street Address)

\_\_\_\_\_  
(City/State/Zip code)

\_\_\_\_\_  
(Attention)

\_\_\_\_\_  
(Telephone)

**IF ANY OF YOUR OUTBOUND SHIPPING INFORMATION ABOVE HAPPENS TO CHANGE, PLEASE NOTIFY US AS SOON AS POSSIBLE. THE GEORGE FERN COMPANY WILL NOT BE RESPONSIBLE FOR ANY SHIPMENTS SHIPPED OUT INCORRECTLY.**

YOUR PREPRINTED BILL OF LADING & SHIPPING LABELS WILL BE DELIVERED TO YOUR BOOTH DURING SHOW HOURS ON **March 24, 2010**. ONCE YOUR SHIPMENT IS PACKED/LABELED AND READY TO SHIP, PLEASE RETURN THE BILL OF LADING (COMPLETE WITH PIECE COUNT & ESTIMATED WEIGHT) TO THE EXHIBITOR SERVICE DESK. **SHIPMENTS LEFT ON THE FLOOR WITHOUT PAPERWORK TURNED IN WILL BE FORCED WITH OUR OFFICIAL CARRIER AT THE EXHIBITOR'S EXPENSE.**

Return to:  
**George Fern Company**

Expositions • Corporate Events • Exhibits

Nationwide

3752 Crittenden Drive Louisville, Kentucky 40209-1122  
 Telephone: 502.367.0254 Fax: 502.368.0284

**WIRE MESH GRIDS  
 ORDER FORM**

**DEADLINE** **March 9, 2010**  
 for return of this form:

**CANCELLATION:** Cancellation after deadline will be charged at 50% of prevailing rate.

**LATE REQUEST:** Request received after deadline will be filled as available, at the standard rate.

**WIRE MESH GRID SYSTEM**

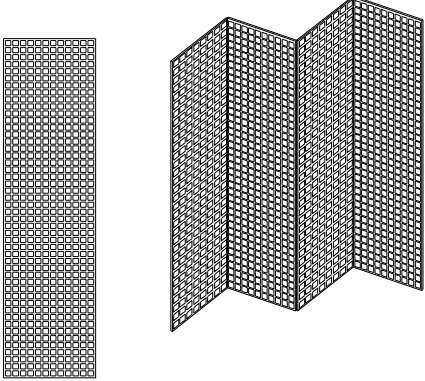
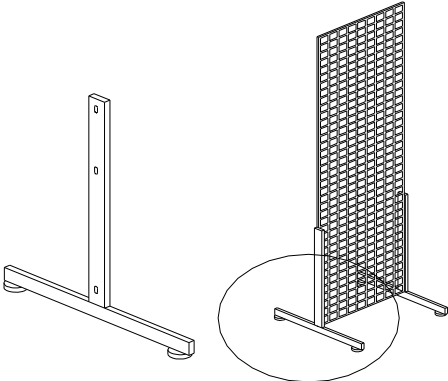
<b>475</b>	<b>GRID PANELS</b> BLACK 24" X 96" (Price per panel)	<b>476</b>	<b>GRID LEGS</b> BLACK (Price per leg)
			

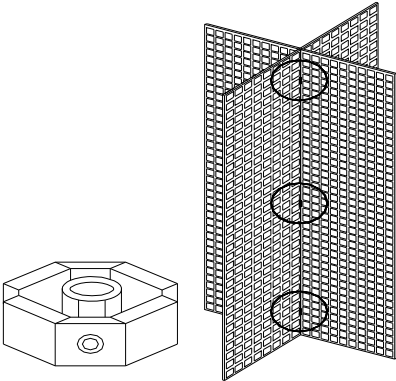
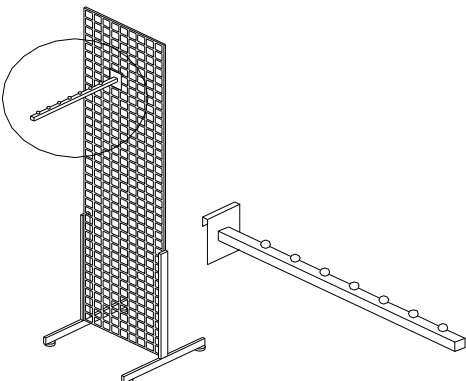
<b>477</b>	<b>4-WAY CONNECTORS</b> CONNECTS 4 GRID PANELS @ 90° ANGLE (Price each connector)	<b>478</b>	<b>7-WAY WATERFALL</b> BLACK (Price each)
			

Quantity	Style (See Illustrations)	Discount Rate	Standard Rate	Quantity	Style (See Illustrations)	Discount Rate	Standard Rate
___	(475) Grid Panel, 2' x 8'	\$ 67.00 ea. ....	<b>\$ 90.50 ea</b>	___	(476) Grid Legs	\$ 10.50 ea. ....	<b>\$ 14.25 ea</b>
___	(477) 4-Way Connector	\$ 2.25 ea. ....	<b>\$ 3.00 ea</b>	___	(478) 7-Way Waterfall	\$ 8.25 ea. ....	<b>\$ 11.25 ea</b>

**Yes, I have completed and enclosed the Payment Form**

No credit will be given after close of event on items or services ordered, but not received.  
 If you have a problem please see Geo. E. Fern Co. Service Personnel at the event site prior to opening.

➡ **Sub Total :** \$ \_\_\_\_\_  
**6% State Tax :** \$ \_\_\_\_\_  
**Total :** \$ \_\_\_\_\_

Name of Event **Louisville Career Expo #4-7905-10** Booth# \_\_\_\_\_ Phone ( ) \_\_\_\_\_

Firm Name \_\_\_\_\_ Fax # ( ) \_\_\_\_\_

Address \_\_\_\_\_ E-Mail \_\_\_\_\_

Street City State Zip Code

Print/Type Name \_\_\_\_\_ Signature \_\_\_\_\_ Date \_\_\_\_\_

All orders are subject to the terms and conditions as outlined on the payment form.

Return to:  
**George Fern Company**

Expositions • Corporate Events • Exhibits

Nationwide

3752 Crittenden Drive Louisville, Kentucky 40209-1122  
 Telephone: 502.367.0254 Fax: 502.368.0284

**PANELBOARD RENTAL  
 ORDER FORM**

**DEADLINE** **March 9, 2010**

for return of this form:

**Cancellation:** Cancellation after deadline will be 50% of prevailing rate.

**Late Request:** Request after deadline will be filled as available at the standard rate.

**Color Choice:** Choices not indicated will be selected by George Fern Co.

**PLEASE INDICATE TYPE AND STYLE OF PANEL REQUIRED.**

**BULLETIN BOARDS** **STYLES**

Quantity	Style <small>(See Illustrations) ⇨</small>	Discount Rate	Standard Rate
___ (603)	4' x 8' Grey Velcro Style H & V only	\$ 90.00 ea...	<b>\$117.00 ea</b>

(Circle One)

**TACKBOARD**

Quantity	Style <small>(See Illustrations) ⇨</small>	Discount Rate	Standard Rate
___ (611)	4' x 8' tackboard panel	\$110.00 ea. ...	<b>\$143.00 ea</b>
___ (609)	2' x 8' tackboard panel	\$ 90.00 ea.....	<b>\$117.00 ea</b>

Covered in your selection of colored vinyl to coordinate with your display.

<input type="checkbox"/> (06) Blue	<input type="checkbox"/> (08) Yellow	<input type="checkbox"/> (04) Black	<input type="checkbox"/> (14) Red
<input type="checkbox"/> (16) White	<input type="checkbox"/> (11) Maroon	<input type="checkbox"/> (10) Green	<input type="checkbox"/> (07) Brown

**PERFORATED BOARD**

Quantity	Style <small>(See Illustrations) ⇨</small>	Discount Rate	Standard Rate
___ (615)	4' x 8' perf. board panel	\$ 90.00 ea. ....	<b>\$117.00 ea</b>
___ (613)	2' x 8' perf. board panel	\$ 75.00 ea.....	<b>\$ 97.50 ea</b>

Perforated board is painted white but may be painted in a solid color of your selection at additional cost of ...

___ (619)	Special color for 4'x8' (additional)	\$ 50.00 ea.....	<b>\$ 65.00 ea</b>
___ (617)	Special color for 2'x8' (additional)	\$ 50.00 ea.....	<b>\$ 65.00 ea</b>

Specify color \_\_\_\_\_

Perforated board hooks NOT provided. 1/4" size hooks required.

**SHELVING (FOR PERORATED BOARD ONLY)**

Quantity	Style <small>(See Illustrations) ⇨</small>	Discount Rate	Standard Rate
___ (631)	4' long x 6" deep-white	\$ 12.00 ea. ....	<b>\$ 15.50 ea</b>
___ (635)	8' long x 6" deep-white	\$ 21.00 ea.....	<b>\$ 27.50 ea</b>
___ (637)	Special color (per shelf addition)	\$ 12.00 ea.....	<b>\$ 15.50 ea</b>

Specify color \_\_\_\_\_

**LABOR (REQUIRED FOR STYLE B & C)**

___ (1036)	hr. labor s/t	\$58.50
___ (1036)	hr. labor o/t	\$117.00

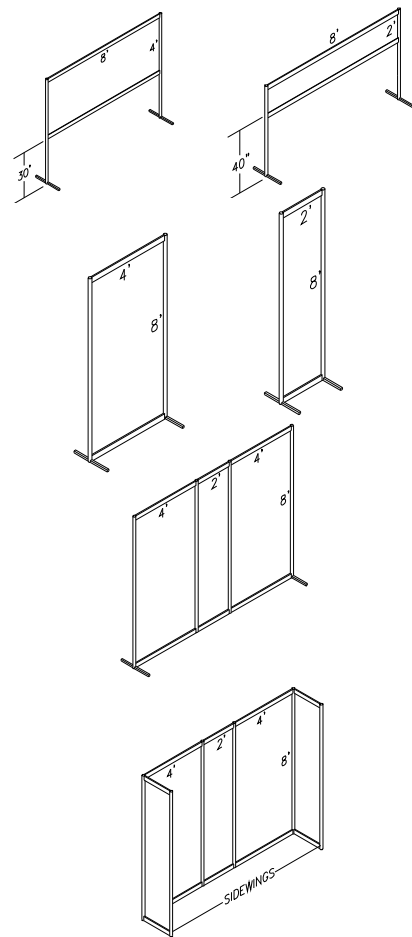

**STYLE "H"**  
**Horizontal**  
 (1) 4' x 8'  
 (1) 2' x 8'

**STYLE "V"**  
**Vertical**  
 (1) 4' x 8'  
 (1) 2' x 8'

**STYLE "B"**  
 Style B requires  
 (2) 4' x 8' panels  
 and (1) 2' x 8' panel  
 per 10' wide backboard.  
 \*Plus labor to install  
 minimum 1 hour

**STYLE "C"**  
 Style B requires  
 (2) 4' x 8' panels and  
 (1) 2' x 8' panel per 10'  
 backboard. Side wings  
 can be ordered as either  
 (2) 4' x 8' panels or  
 (2) 2' x 8' panels.  
 \*Plus labor to install  
 minimum 1 hour

Please indicate below the desired depth of side wings and be sure to include side wing returns in your order for Style "C".

2' deep  4' deep

**Yes, I have completed and enclosed the Payment Form**  
 No credit will be given after close of event on items or services ordered, but not received. If you have a problem please see the George Fern Co. Service Desk Personnel at the event site prior to leaving.

⇨ **Sub Total Equipment ( taxable):** \$ \_\_\_\_\_  
**6% Tax on Equipment:** \$ \_\_\_\_\_  
**Labor:** \$ \_\_\_\_\_  
**Total:** \$ \_\_\_\_\_

Name of Event **Louisville Career Expo #4-7905-10** Booth# \_\_\_\_\_ Phone ( ) \_\_\_\_\_  
 Firm Name \_\_\_\_\_ Fax # ( ) \_\_\_\_\_  
 Address \_\_\_\_\_ E-Mail \_\_\_\_\_  
 Street City State Zip Code  
 Print/Type Name \_\_\_\_\_ Signature \_\_\_\_\_ Date \_\_\_\_\_

Return to:  
**George Fern Company**

Expositions • Corporate Events • Exhibits

Nationwide

3752 Crittenden Drive Louisville, Kentucky 40209-1122  
 Telephone: 502.367.0254 Fax: 502.368.0284

**SIGN AND ART WORK  
 ORDER FORM**

**DEADLINE** **March 9, 2010**

for return of this form:

**Cancellation:** No refunds on orders cancelled after deadline.

**Late Request:** Request after deadline will be filled as available at the standard rate.

**Color Choice:** Choices not indicated will be selected by George Fern Co.

This form is to be used for ordering special signs or artwork (NOT your booth I.D. Sign). There are two types of sign styles available to choose from. The first is signs created using computer cut vinyl graphics. These are good for one, two, or three color simple signs in solid colors. For more elaborate artwork with color gradients, we offer full color digital signs. Complex process color logos are an example of this. Prices indicated below are based on preparation of sign from customer copy or, if digital, computerized artwork supplied.

PRESSURE SENSITIVE VINYL SIGNS	FOUR COLOR DIGITAL SIGNS
--------------------------------	--------------------------

Prices indicated below are based upon 10 words per card and one color copy on white background. Signs other than sizes listed below will be prepared on a pro-rata price basis. Minimum order - \$ 30.00

Qty.	Code	Description	Discount Rate	Standard Rate	Amount
___	(801)	7" x 11" Card .....	\$ 35.00	.... \$ <b>52.50</b>	\$ _____
___	(803)	11" x 14" Card .....	\$ 40.00	.... \$ <b>60.00</b>	\$ _____
___	(805)	14" x 22" Card .....	\$ 45.00	.... \$ <b>67.50</b>	\$ _____
___	(807)	7" x 44" Card .....	\$ 45.00	.... \$ <b>67.50</b>	\$ _____
___	(811)	14" x 44" Card .....	\$ 65.00	.... \$ <b>97.50</b>	\$ _____
___	(813)	22" x 28" Card .....	\$ 70.00	.... \$ <b>105.00</b>	\$ _____
___	(815)	28" x 44" Card .....	\$ 90.00	.... \$ <b>135.00</b>	\$ _____
___	(819)	24" x 96" Foamcore .....	\$ 200.00	.... \$ <b>300.00</b>	\$ _____
___	(821)	48" x 96" Foamcore .....	\$ 250.00	.... \$ <b>375.00</b>	\$ _____
___	(899)	Other _____ x _____	Call for Quote		\$ _____
___	(827)	Easel back for card signs .	\$ 10.00	.... \$ <b>15.00</b>	\$ _____
___	(829)	Words in excess of 10 .....	\$ 1.50	.... \$ <b>2.25</b>	\$ _____
___	(831)	Colored card .....	\$ 7.50	.... \$ <b>11.25</b>	\$ _____
___	(833)	Additional color lettering \$	7.50	.... \$ <b>11.25</b>	\$ _____

Prices indicated below are based upon process color printing, mounting, and laminating on showcard or foamcore. Signs other than sizes listed below will be prepared on a sq/ft basis, rounded to the nearest 1/2 ft. x 1/2 ft. Minimum order - \$ 35.00

Qty.	Code	Description	Discount Rate	Standard Rate	Amount
___	(861)	7" x 11" Card .....	\$ 45.00	.... \$ <b>67.50</b>	\$ _____
___	(863)	11" x 14" Card .....	\$ 50.00	.... \$ <b>75.00</b>	\$ _____
___	(865)	14" x 22" Card .....	\$ 60.00	.... \$ <b>90.00</b>	\$ _____
___	(867)	7" x 44" Card .....	\$ 60.00	.... \$ <b>90.00</b>	\$ _____
___	(871)	14" x 44" Card .....	\$ 85.00	.... \$ <b>127.50</b>	\$ _____
___	(873)	22" x 28" Card .....	\$ 90.00	.... \$ <b>135.00</b>	\$ _____
___	(875)	28" x 44" Card .....	\$ 105.00	.... \$ <b>157.50</b>	\$ _____
___	(879)	24" x 96" Foamcore .....	\$ 264.00	.... \$ <b>396.00</b>	\$ _____
___	(881)	48" x 96" Foamcore .....	\$ 576.00	.... \$ <b>864.00</b>	\$ _____
___	(882)	Other _____ x _____	\$16.50sq/ft.	\$24.75sq/ft	\$ _____
___	(883)	Senra _____ x _____	\$18.00sq/ft.	\$27.00sq/ft	\$ _____
___	(827)	Easel back for card signs .	\$ 10.00	.... \$ <b>15.00</b>	\$ _____

Emblems, trademarks, logos, special style lettering, etc., can be prepared at extra cost depending on size and amount of work involved in production. Advance quotations can be provided upon submission of copy.

Emblems, trademarks, logos, special style lettering, etc., are *inclusive* of the above prices, if provided to us in digital format. Please provide in a PC vector format if available, or PC Raster is the second option. If you can only provide in Mac format, we will attempt to convert, but cannot guarantee 100% accuracy in conversion. If you have any questions on formats supported, please call.

PLEASE INDICATE COLOR OF SIGN AND LETTERING:	PLEASE CHECK TYPE OF SIGN DESIRED:
--	------------------------------------

COLOR OF BACKGROUND _____	COLOR OF LETTERING _____
---------------------------	--------------------------

Vertical Sign <input type="checkbox"/>	Horizontal Sign <input type="checkbox"/>
--	--

INDICATE SIGN COPY
--------------------

[ ] See Attached

**Yes, I have completed and enclosed the Payment Form**

No credit will be given after close of event on items or services ordered, but not received. If you have a problem please see the George Fern Co. Service Desk Personnel at the event site prior to leaving.

**Sub Total:** \$ \_\_\_\_\_  
**6% State tax:** \$ \_\_\_\_\_  
**TOTAL:** \$ \_\_\_\_\_

Name of Event **Louisville Career Expo #4-7905-10** Booth# \_\_\_\_\_ Phone ( ) \_\_\_\_\_  
 Firm Name \_\_\_\_\_ Fax # ( ) \_\_\_\_\_  
 Address \_\_\_\_\_ E-Mail \_\_\_\_\_  
 Street City State Zip Code  
 Print/Type Name \_\_\_\_\_ Signature \_\_\_\_\_ Date \_\_\_\_\_

All orders are subject to the terms and conditions as outlined on the payment form.

Return to:  
**George Fern Company**

Expositions • Corporate Events • Exhibits

Nationwide

3752 Crittenden Drive Louisville, Kentucky 40209-1122  
 Telephone: 502.367.0254 Fax: 502.368.0284

**AUDIO-VISUAL EQUIPMENT  
 RENTAL ORDER FORM**

**DEADLINE** **March 9, 2010**  
 for return of this form:

**Cancellation:** Cancellation after deadline will be 75% of prevailing rate.  
**Late Request:** Request after deadline will be filled as available at the standard rate.

Delivery of Audio Visual equipment is conducted approximately 1 hour PRIOR to show opening. A Booth Delivery / Pick-up Charge of \$60.00 will be assessed on all Audio Visual Orders. This charge is non-taxable, and is included in the calculations below. Equipment will be removed immediately following final closing of event. If you have a need for any equipment that is not listed below, please direct your inquiries to the address, fax or phone number listed above.

**FLAT PANEL DISPLAYS**

QUANTITY	DESCRIPTION	DISCOUNT RATE	STANDARD RATE	EXTENSION
_____	(1803) 15" Flat Panel Display - (Computer Only)	\$ 200.00 .....	\$ <b>280.00</b>	_____
_____	(1805) 17" Flat Panel Display - (Computer Only)	\$ 280.00 .....	\$ <b>392.00</b>	_____
_____	(1806) 19" Flat Panel Display - (Video or Computer, w/speakers)	\$ 390.00 .....	\$ <b>546.00</b>	_____
_____	(1810) 26" Flat Panel Display - (Video or Computer, w/speakers)	\$ 650.00 .....	\$ <b>910.00</b>	_____
_____	(1812) 32" Flat Panel Display - (Video or Computer, w/speakers)	\$ 900.00 .....	\$ <b>1260.00</b>	_____
_____	(1760) 42" Plasma Panel - (Video or Computer, w/speakers)	\$ 1450.00 .....	\$ <b>2030.00</b>	_____
_____	(1762) 50" Plasma Panel	\$ 2100.00 .....	\$ <b>2940.00</b>	_____
_____	(1763) Dual Post Stand for 42" or 50" Plasma Panel	\$ 250.00 .....	\$ <b>350.00</b>	_____

**AUDIO / VIDEO EQUIPMENT**

QUANTITY	DESCRIPTION	DISCOUNT RATE	STANDARD RATE	EXTENSION
_____	(1746) 20" Monitor/VHS Package (Includes Monitor, 1/2" VHS, Cart)	\$ 295.00 .....	\$ <b>413.00</b>	_____
_____	(1752) 27" Monitor/VHS Package (Includes Monitor, 1/2" VHS, Cart)	\$ 335.00 .....	\$ <b>469.00</b>	_____
_____	(1753) 20" Monitor/DVD Package (Includes Monitor, DVD, Cart)	\$ 295.00 .....	\$ <b>413.00</b>	_____
_____	(1755) 27" Monitor/DVD Package (Includes Monitor, DVD, Cart)	\$ 335.00 .....	\$ <b>469.00</b>	_____
_____	(1708) 20" Video Monitor	\$ 180.00 .....	\$ <b>252.00</b>	_____
_____	(1712) 27" Video Monitor	\$ 220.00 .....	\$ <b>308.00</b>	_____
_____	(1714) 32" Video Monitor	\$ 390.00 .....	\$ <b>546.00</b>	_____
_____	(1726) 1/2" VHS Player (w/ Auto Repeat)	\$ 97.50 .....	\$ <b>136.50</b>	_____
_____	(1794) DVD Player	\$ 97.50 .....	\$ <b>136.50</b>	_____
_____	(1778) LCD Projector	\$ 650.00 .....	\$ <b>910.00</b>	_____
_____	(1830) Tripod Screen - (circle size: 5' 6' 7' 8')	\$ 50.00 .....	\$ <b>70.00</b>	_____
_____	(1784) Sound System - (250 W, 4 Channel, 2 Speakers, 1 Mic)	\$ 390.00 .....	\$ <b>546.00</b>	_____
_____	(1787) Wireless Mic Sound System - (Handheld or Lavalier)	\$ 665.00 .....	\$ <b>931.00</b>	_____

**RENTAL AGREEMENT:** It is understood and agreed the customer is renting the equipment for a specific period only, and is responsible for its safe return. Customer agrees to be billed for *any* loss of, or damage to, rented equipment.

No credit will be given after close of event on items or services ordered, but not received. If you have a problem please see the George Fern Co. Service Desk personnel at the event site prior to opening.

Charges listed above are rental rates (not sale). If technician is required, an added cost may be incurred.

➔ **Sub Total Equipment ( taxable):** \$ \_\_\_\_\_  
**6% Tax on Equipment:** \$ \_\_\_\_\_  
**Booth Delivery / Pick-up Fee:** \$ **60.00**  
**Total:** \$ \_\_\_\_\_

**Yes, I have completed and enclosed the Payment Form**

Name of Event **Louisville Career Expo #4-7905-10** Booth# \_\_\_\_\_ Phone ( ) \_\_\_\_\_  
 Firm Name \_\_\_\_\_ Fax # ( ) \_\_\_\_\_  
 Address \_\_\_\_\_ E-Mail \_\_\_\_\_  
 Street City State Zip Code  
 Print/Type Name \_\_\_\_\_ Signature \_\_\_\_\_ Date \_\_\_\_\_

Return to:  
**George Fern Company**

Expositions • Corporate Events • Exhibits

Nationwide

3752 Crittenden Drive Louisville, Kentucky 40209-1122  
 Telephone: 502.367.0254 Fax: 502.368.0284

**FLORAL RENTAL  
 ORDER FORM**

**DEADLINE** **March 9, 2010**  
 for return of this form:

**Cancellation:** Cancellation after deadline will be 75% of prevailing rate.  
**Late Request:** Request after deadline will be filled as available at the standard rate.  
**Color Choice:** Choices not indicated will be selected by George Fern Co.

*Please indicate Selections by Circling*

POTTED PLANTS - Indicate Color Selection		DISCOUNT	STANDARD	COST
Qty. _____	(1501) Azaleas - Live available in season .....	\$45.00 .....	\$ 60.75	_____
Qty. _____	(1502) Bromeliads - Live, available in season .....	\$50.00 .....	\$ 67.50	_____
Qty. _____	(1503) Chrysanthemums - Live, White / Yellow .....	\$45.00 .....	\$ 60.75	_____
Qty. _____	(1505) Ferns - Live, Floor / Hanging .....	\$50.00 .....	\$ 67.50	_____

TROPICAL GREEN PLANTS		DISCOUNT	STANDARD	COST
Qty. _____	(1507) 3 Ft. - Slim / Full .....	\$65.00 .....	\$ 87.25	_____
Qty. _____	(1509) 4 Ft. - Slim / Full .....	\$75.00 .....	\$101.25	_____
Qty. _____	(1511) 5 Ft. - Slim / Full .....	\$85.00 .....	\$114.75	_____
Qty. _____	(1513) 6 Ft. - Slim / Full .....	\$95.00 .....	\$128.25	_____
Qty. _____	(1515) 7 Ft. - Slim / Full .....	\$105.00 .....	\$141.75	_____

ALL CONTAINERS FOR TROPICAL GREEN PLANTS WILL BE PROVIDED IN A WHITE WICKER OR DARK RATTAN  
 PLEASE CIRCLE CHOICE: WHITE DARK

FLOWER ARRANGEMENTS - Indicate Color Selection		DISCOUNT	STANDARD	COST
Qty. _____	(1545) Table Top, 10" Baskets of cut flowers .....	\$100.00 to .....	\$135.00 to _____	
	Style: Center Piece - Tall, Low, One Sided .....	\$150.00	\$202.50	
	Colors: White, Yellow, Rust, Lavender, Blue, Pastels			

**SPECIAL REQUIRMENTS AND LANDSCAPING - other than items listed above**

Prices on bark, moss, fencing, fountains, (1573) hedge plants, (1599) general landscaping are available when submitting "To Scale Layout of Desired". Feel free to phone us to discuss or fax your layout to the number indicated on the letterhead above. If you wish, we can have a representative visit your exhibit space.

**COMPLETE THE FOLLOWING ONLY IF YOU HAVE REQUIREMENTS OTHER THAN THOSE LISTED ABOVE:**

\* (1599) Please have florist come to our Booth No. \_\_\_\_\_ at \_\_\_\_\_ A.M. / P.M. on \_\_\_\_\_ and see our Representative \_\_\_\_\_ for instructions.  
 Please provide telephone # ( \_\_\_\_\_ ) \_\_\_\_\_ where representative can be reached in advance.

**Yes, I have completed and enclosed the Payment Form**

No credit will be given after close of event on items or services ordered, but not received. If you have a problem please see George Fern Co. Service Personnel at the event site prior to opening.

**Sub Total:** \$ \_\_\_\_\_  
 6% State tax: \$ \_\_\_\_\_  
**TOTAL:** \$ \_\_\_\_\_

Name of Event **Louisville Career Expo #4-7905-10** Booth# \_\_\_\_\_ Phone ( \_\_\_\_\_ ) \_\_\_\_\_  
 Firm Name \_\_\_\_\_ Fax # ( \_\_\_\_\_ ) \_\_\_\_\_  
 Address \_\_\_\_\_ E-Mail \_\_\_\_\_  
 Street City State Zip Code  
 Print/Type Name \_\_\_\_\_ Signature \_\_\_\_\_ Date \_\_\_\_\_

All orders are subject to the terms and conditions as outlined on the payment form.

Return to:  
**George Fern Company**  
 Expositions • Corporate Events • Exhibits  
Nationwide

3752 Crittenden Drive Louisville, Kentucky 40209-1122  
 Telephone: 502.367.0254 Fax: 502.368.0284

**THANK YOU  
 RESPONSE FORM**

**DEADLINE** **March 9, 2010**  
 for return of this form:

**PLEASE READ CAREFULLY AND  
 RESPOND BY DEADLINE**

Thank you for reviewing the enclosed order forms. This form has been provided to eliminate unnecessary follow-up mailings and telephone calls to you if you have no need for exhibit furnishings and/or services or if you do not anticipate placing your order until you arrive at event site .....  
**PLEASE RESPOND TO THE FOLLOWING:**

**PLEASE CHECK ONE:**

**(T) NO ORDER**

After reviewing the enclosed order forms, we have determined that *we will not require* any furnishings or services from the George Fern Co.

**(W) WILL ORDER AT EVENT SITE**

We are unable to request our needs in advance; however, we *do anticipate ordering* items and/or services at prevailing rates & conditions from the following categories when we arrive at event site (please check):

- |                               |                                       |
|-------------------------------|---------------------------------------|
| _____ Exhibit Furniture       | _____ Panelboard                      |
| _____ Exhibit / Custom Carpet | _____ Display Labor                   |
| _____ Sign / Artwork          | _____ Cleaning                        |
| _____ In-Booth Forklift       | _____ Drayage / Freight Services      |
| _____ Floral Rental           | _____ Audio / Visual Equipment Rental |
| _____ Wire Mesh Grid          |                                       |
| _____ Misc. (list) _____      |                                       |

*(Some furnishings and/or services listed above may not be available at this particular event. Please check order forms. If not offered, please feel free to inquire with our office. Also note that you may find some services above are provided by someone other than George Fern Co. See letterhead of each form and contact appropriate company regarding your intent to order at event site.)*

**CONTACT SOMEONE ELSE REGARDING OUR EXHIBIT NEEDS**

I am not the person responsible for the ordering of exhibit furnishings and services.  
**PLEASE CONTACT THE FOLLOWING INDIVIDUAL:**

Name \_\_\_\_\_ Phone (        ) \_\_\_\_\_  
 Company Name \_\_\_\_\_  
 Mailing Address \_\_\_\_\_  
 City / State / Zip \_\_\_\_\_

**PLEASE RETURN THIS FORM TO AVOID UNNECESSARY MAILINGS AND CALLS !**

Name of Event **Louisville Career Expo #4-7905-10** Booth# \_\_\_\_\_ Phone (        ) \_\_\_\_\_  
 Firm Name \_\_\_\_\_ Fax # (        ) \_\_\_\_\_  
 Address \_\_\_\_\_ E-Mail \_\_\_\_\_  
Street City State Zip Code  
 Print/Type Name \_\_\_\_\_ Signature \_\_\_\_\_ Date \_\_\_\_\_

Return to:  
**George Fern Company**  
 Expositions • Corporate Events • Exhibits  
Nationwide

3752 Crittenden Drive Louisville, Kentucky 40209-1122  
 Telephone: 502.367.0254 Fax: 502.368.0284

**INDEPENDENT DISPLAY HOUSE/  
 CONTRACTOR NOTIFICATION**

**DEADLINE** **March 9, 2010**  
 for return of this form:

Complete and return this form by Deadline only if you are planning to use any company other than George Fern Co. for the installation or dismantling of your exhibit.

**INDEPENDENT DISPLAY HOUSE CONTRACTORS**

Yes, we will be using an independent display house/contractor to install and/or dismantle our display at the Louisville Career Expo in Louisville, KY and have completed the following information.

Exhibiting Company Name: \_\_\_\_\_ Booth No. \_\_\_\_\_  
 Exhibiting Contact Person: \_\_\_\_\_  
 Exhibiting Company Telephone Number: \_\_\_\_\_  
 Contractor To Be Utilized (Company Name): \_\_\_\_\_  
 Address: \_\_\_\_\_  
 Contractor Telephone Number: \_\_\_\_\_  
 Contractor Contact Name: \_\_\_\_\_

**INDICATE WHAT SERVICES ARE TO BE CHARGED TO THIRD PARTY**

\* See the letterhead of each individual order form to confirm what company is providing services ordered on that specific form. This third party billing information above and below is for use by George Fern Company only, therefore if a service that you have ordered is being provided by someone other than George Fern Company, you need **not** indicate that particular service below:

- |  |   |
|--|---|
| _____ (01) EXHIBIT FURNITURE RENTAL ORDER      | _____ (03) EXHIBIT / CUSTOM CARPET RENTAL ORDER |
| _____ (06) PANELBOARD RENTAL ORDER             | _____ (10) IN-BOOTH FORKLIFT                    |
| _____ (08) SIGN AND ART WORK ORDER             | _____ (10) DISPLAY LABOR                        |
| _____ (12) DRAYAGE SERVICES ORDER              | _____ (09) CLEANING SERVICES ORDER              |
| _____ (15) FLORAL RENTAL ORDER                 |   |
| _____ (17) AUDIO/VISUAL EQUIPMENT RENTAL ORDER |   |
| _____ (99) MISCELLANEOUS - LIST _____          |   |

NOTE: Some order forms for furnishings and/or services listed above may not be enclosed if a specific service or item is not offered on this event.  
 If you have any questions, please contact George Fern Co.  
 \* Exhibiting company clearly understand that exhibiting company is ultimately responsible for payment of any and all services invoiced third party which remain unpaid at close of show.

I have notified our independent display house/contractor of the rules and regulations requiring them to submit a Certificate of Insurance to the Official Show Contractor, George Fern Company, by above Deadline Date.

Signature \_\_\_\_\_ Date \_\_\_\_\_ Print or Type Your Name \_\_\_\_\_

Name of Event **Louisville Career Expo #4-7905-10** Booth# \_\_\_\_\_ Phone ( ) \_\_\_\_\_  
 Firm Name \_\_\_\_\_ Fax # ( ) \_\_\_\_\_  
 Address \_\_\_\_\_ E-Mail \_\_\_\_\_  
 Street City State Zip Code  
 Print/Type Name \_\_\_\_\_ Signature \_\_\_\_\_ Date \_\_\_\_\_

## **Policy Regarding Official Service Contractor And Regulations For Exhibitor Appointed Independent Display House Contractors To Install and Dismantle Displays**

The Official Service Contractor is appointed to:

- a. Insure the orderly and efficient installation and removal of the overall exposition,
- b. Assure the distribution of labor to all Exhibitors according to the need,
- c. Provide sufficient labor to satisfy the requirements of Exhibitors, and for the exposition itself,
- d. See that the proper type and limits of insurance are in force, and
- e. Avoid any conflict with local union and/or exhibit hall regulations and requirements.

The Official Service Contractor will provide all usual trade show services, including labor. Exceptions are:

- f. Supervision may be provided by the Exhibitor.
- g. The Exhibitor may appoint an outside independent contractor for installation and dismantle only of the Exhibitor's display.

Exhibitors may employ the service of independent contractors to supervise the installation and dismantlement of their displays, providing the Exhibitor and the installation and dismantling contractor comply with the following requirement:

1. The Exhibitor, in writing, must notify Show Management and George Fern Co. of their intention to utilize an independent contractor no later than 25 days prior to the first move-in day, furnishing the name, address and telephone number of the firm. Letters such as from independent contractors are neither valid nor acceptable.
2. Only the one Exhibitor named independent contractor's employees will be authorized on the show floor. Employees of third parties named or subcontracted by the Exhibitor named independent contractor will not be authorized admittance on the show floor unless those employees are named and badged as specified in the following article.
3. The independent contractor must furnish Show Management and George Fern Co. with the names of all on-site employees who will be working on the exposition floor prior to the first move-in day and see that they have and wear at all times identification badges supplied by the independent contractor containing the independent contractor name, employee name and Exhibitor Company name, plus wear an exhibitor work pass supplied by Show Management.
4. The independent contractor must have all business licences, permits and Workman's Compensation insurance required by the State and City governments and the Convention Center Management prior to commencing work, and shall provide Show Management and George Fern Co. with evidence of compliance.
5. The independent contractor must carry a minimum of \$1,000,000 in Public Liability Insurance and shall provide Show Management and George Fern Co. with a certificate of insurance showing the coverages and amounts, and naming the sponsor, George Fern Co. and the Convention Center as co-insured.
6. The independent contractor must follow the scheduled work times or pay any additional costs incurred because of extended work hours.
7. The independent contractor may not solicit business on the exhibit floor.
8. The independent contractor must confine their operations to the exhibit area of their clients. No service desks, storage areas or other work facilities will be located anywhere else in the building. The show aisles and public space are not part of the Exhibitor's booth space.
9. The independent contractor must comply with all labor agreements and practices and must not commit or allow to be committed by persons in their employment any acts that could lead to work stoppages, strikes or labor problems.
10. The exposition floor, aisles, loading docks, services and storage areas will be under the control of the Official George Fern Co.
11. For services such as electrical, plumbing, telephone floral, booth cleaning and drainage, no contractor or support other than the Official Service Contractor/Supplier will be approved. This regulation is necessary because of licensing, insurance, and work done on equipment and facilities owned by parties other than the Exhibitors. Exhibitors shall provide only the material and equipment they own and is to be used in their exhibit space.